

Silicon N-Channel Power MOSFET

General Description:

The HMZ8P03 uses advanced trench technology and design to provide excellent $R_{DS(ON)}$ with low gate charge. It can be used in a wide variety of applications. The package form is SOT-23, which accords with the RoHS standard.

| | | |
|-----------------|-----|------------|
| V_{DSS} | -30 | V |
| I_D | -8 | A |
| P_D | 1.2 | W |
| $R_{DS(ON)MAX}$ | 30 | m Ω |

Features:

- $R_{DS(ON)} < 30m\Omega$ @ $V_{GS}=10V$
- High density cell design for ultra low R_{dson}
- Fully characterized avalanche voltage and current
- Excellent package for good heat dissipation

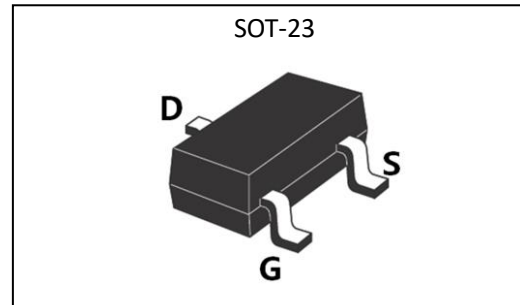

Applications:

- Power switching application
- Hard switched and high frequency circuits
- Uninterruptible power supply

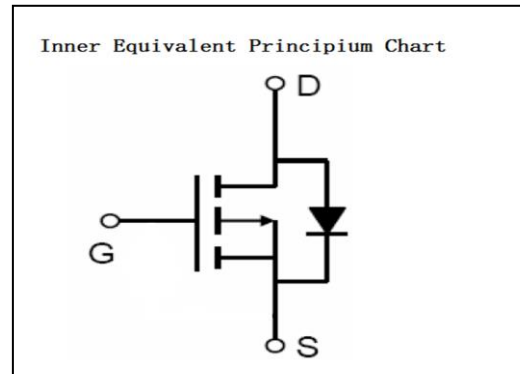

Absolute (Tc= 25°C unless otherwise specified):

| Symbol | Parameter | Rating | Units |
|----------------|--|-----------------|-------------|
| V_{DSS} | Drain-to-Source Voltage | -30 | V |
| I_D | Continuous Drain Current | -8 | A |
| V_{GS} | Gate-to-Source Voltage | ± 12 | V |
| P_D | Power Dissipation | 1.2 | W |
| T_J, T_{stg} | Operating Junction and Storage Temperature Range | 150, -55 to 150 | $^{\circ}C$ |

| Symbol | Parameter | Typ. | Units |
|-----------------|-----------------------------------|-------|---------------|
| $R_{\theta JA}$ | Junction-to-Ambient ^{a2} | 104.1 | $^{\circ}C/W$ |

Electrical Characteristics ($T_c = 25^\circ\text{C}$ unless otherwise specified) :

| OFF Characteristics | | | | | | |
|---------------------|-----------------------------------|--|--------|------|------|---------|
| Symbol | Parameter | Test Conditions | Rating | | | Units |
| | | | Min. | Typ. | Max. | |
| V_{DSS} | Drain to Source Breakdown Voltage | $V_{GS}=0V, I_D=-250\mu A$ | -30 | -- | -- | V |
| I_{DSS} | Drain to Source Leakage Current | $V_{DS}=-24V, V_{GS}=0V, T_a=25^\circ\text{C}$ | -- | -- | -1.0 | μA |
| $I_{GSS(F)}$ | Gate to Source Forward Leakage | $V_{GS}=+12V$ | -- | -- | 0.1 | μA |
| $I_{GSS(R)}$ | Gate to Source Reverse Leakage | $V_{GS}=-12V$ | -- | -- | -0.1 | μA |

| ON Characteristics | | | | | | |
|--|---|-------------------------------|--------|------|------|-----------|
| Symbol | Parameter | Test Conditions | Rating | | | Units |
| | | | Min. | Typ. | Max. | |
| $R_{DS(ON)1}$ | Drain-to-Source On-Resistance ^{a1} | $V_{GS}=-10V, I_D=-4.2A$ | -- | -- | 30 | $m\Omega$ |
| $R_{DS(ON)2}$ | Drain-to-Source On-Resistance ^{a1} | $V_{GS}=-4.5V, I_D=-3.5A$ | -- | -- | 35 | $m\Omega$ |
| $R_{DS(ON)3}$ | Drain-to-Source On-Resistance ^{a1} | $V_{GS}=-2.5V, I_D=-1A$ | -- | -- | 40 | $m\Omega$ |
| $V_{GS(TH)}$ | Gate Threshold Voltage | $V_{DS}=V_{GS}, I_D=250\mu A$ | -0.5 | -- | -1.3 | V |
| Pulse width $t_p \leq 380\mu s, \delta \leq 2\%$ | | | | | | |

| Dynamic Characteristics | | | | | | |
|-------------------------|--|---|--------|------|------|-------|
| Symbol | Parameter | Test Conditions | Rating | | | Units |
| | | | Min. | Typ. | Max. | |
| g_{fs} | Forward Transconductance ^{a1} | $V_{DS}=-5V, I_D=-5A$ | 14 | -- | -- | S |
| C_{iss} | Input Capacitance ^{a2} | $V_{GS}=0V, V_{DS}=-15V$ $f=1.0\text{MHz}$ | -- | 1950 | -- | pF |
| C_{oss} | Output Capacitance ^{a2} | | -- | 210 | -- | |
| C_{rss} | Reverse Transfer Capacitance ^{a2} | | -- | 150 | -- | |

| Resistive Switching Characteristics ^{a2} | | | | | | |
|---|---------------------|---|--------|------|------|-------|
| Symbol | Parameter | Test Conditions | Rating | | | Units |
| | | | Min. | Typ. | Max. | |
| $t_{d(ON)}$ | Turn-on Delay Time | $V_{DD}=-15V, R_L=-3.6\Omega$ $V_{GS}=-10V, R_G=6\Omega$ | -- | -- | 12 | ns |
| t_r | Rise Time | | -- | -- | 6.4 | |
| $t_{d(OFF)}$ | Turn-Off Delay Time | | -- | -- | 75 | |
| t_f | Fall Time | | -- | -- | 24 | |

| Source-Drain Diode Characteristics | | | | | | |
|------------------------------------|-------------------------------------|----------------------|--------|------|------|-------|
| Symbol | Parameter | Test Conditions | Rating | | | Units |
| | | | Min. | Typ. | Max. | |
| V_{SD} | Diode Forward Voltage ^{a1} | $I_S=-4A, V_{GS}=0V$ | -- | -- | -1 | V |

^{a1}: Pulse Test: Pulse Width $\leq 300\mu s$, Duty Cycle $\leq 2\%$.

^{a2}: These parameters have no way to verify

Characteristics Curve:

Typical Electrical and Thermal Characteristics

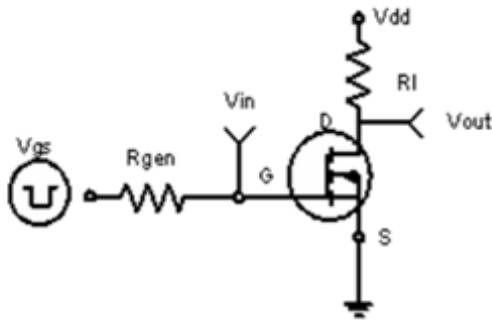

Figure 1: Switching Test Circuit

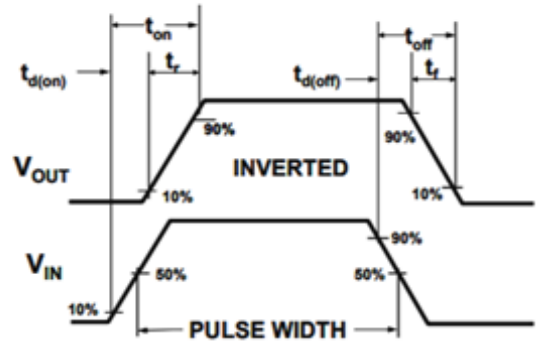
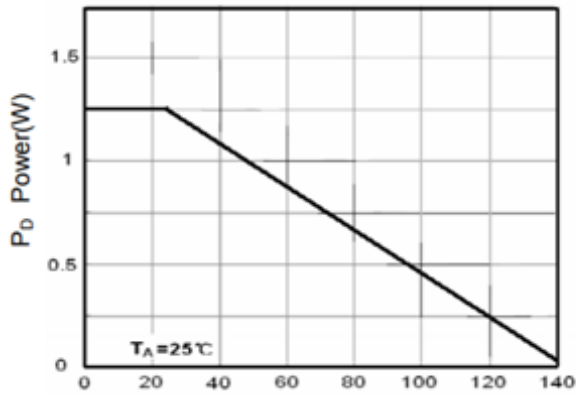
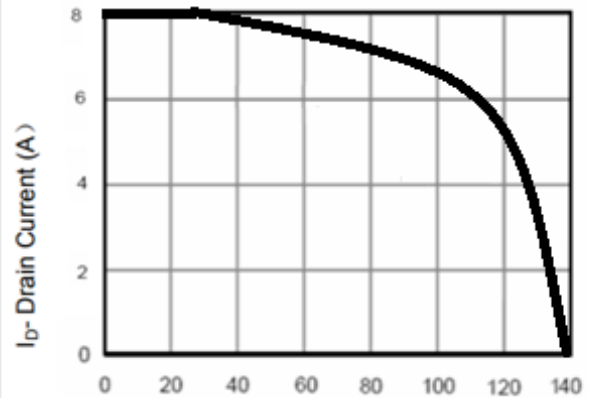

Figure 2: Switching Waveforms



T_J -Junction Temperature($^{\circ}C$)
Figure 3 Power Dissipation



T_J -Junction Temperature($^{\circ}C$)
Figure 4 Drain Current

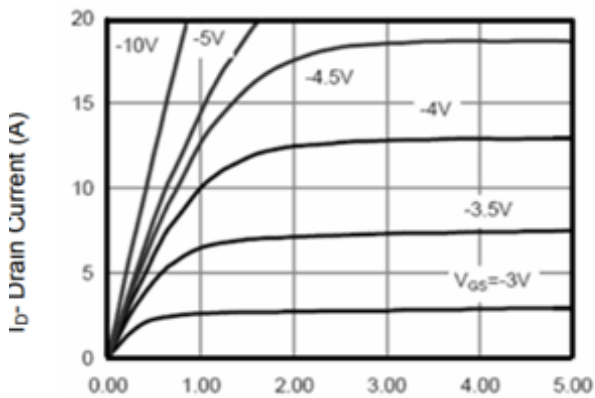

V_{DS} Drain-Source Voltage (V)
Figure 5 Output Characteristics

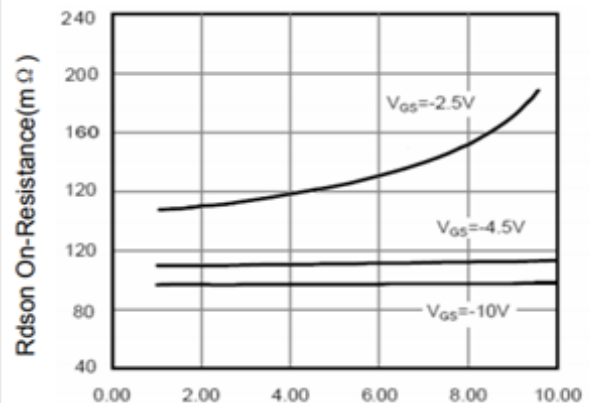

I_D - Drain Current (A)
Figure 6 Drain-Source On-Resistance

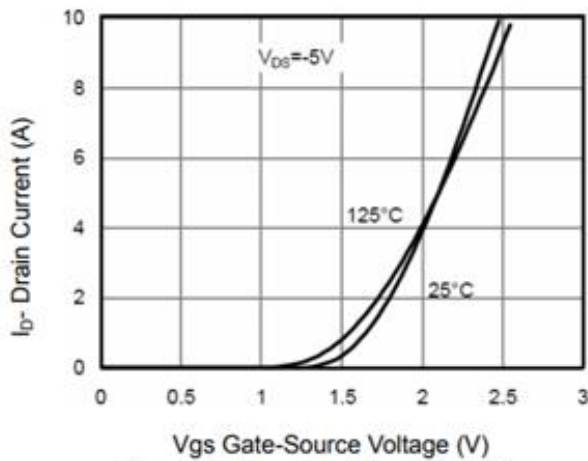

Figure 7 Transfer Characteristics

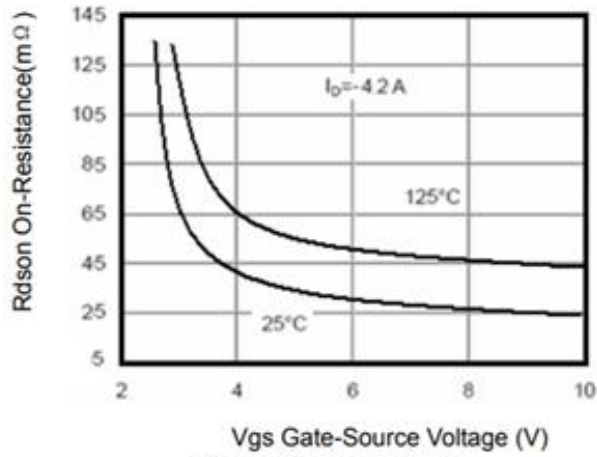

Figure 9 Rdson vs Vgs

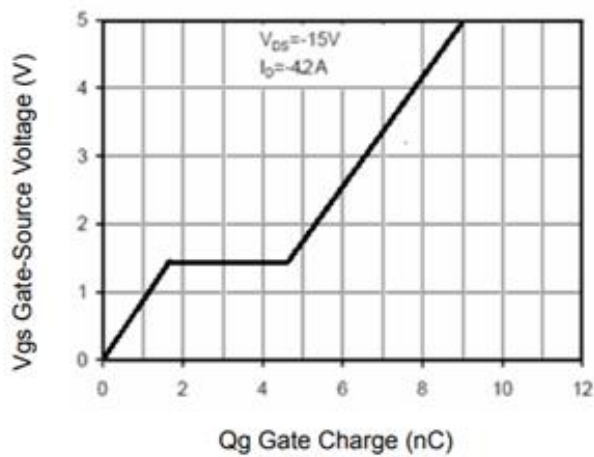

Figure 11 Gate Charge

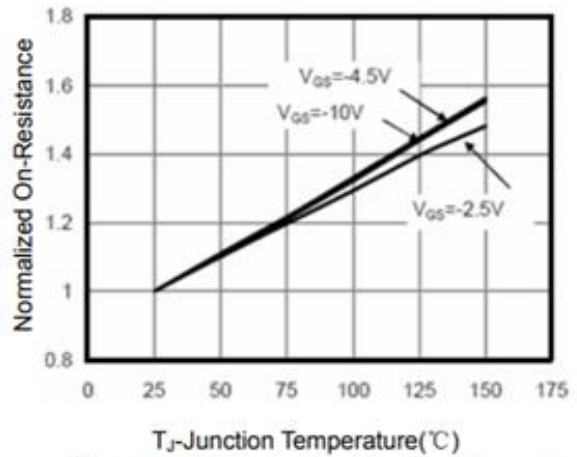

Figure 8 Drain-Source On-Resistance

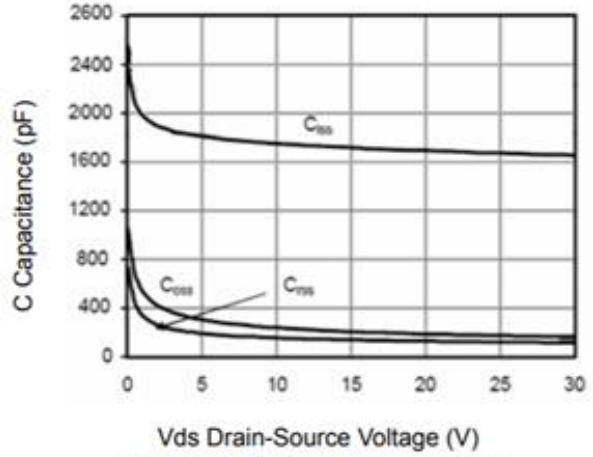

Figure 10 Capacitance vs Vds

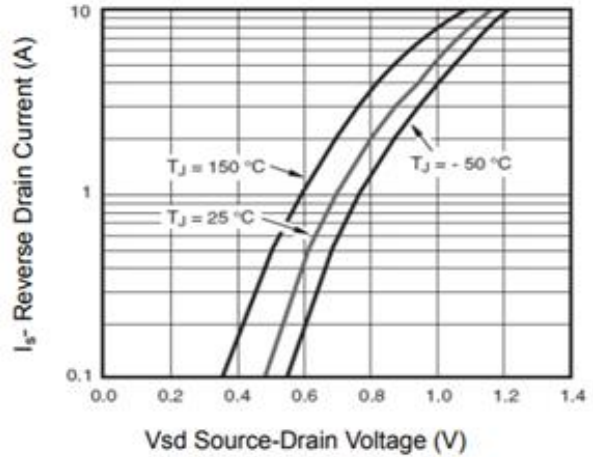

Figure 12 Source- Drain Diode Forward

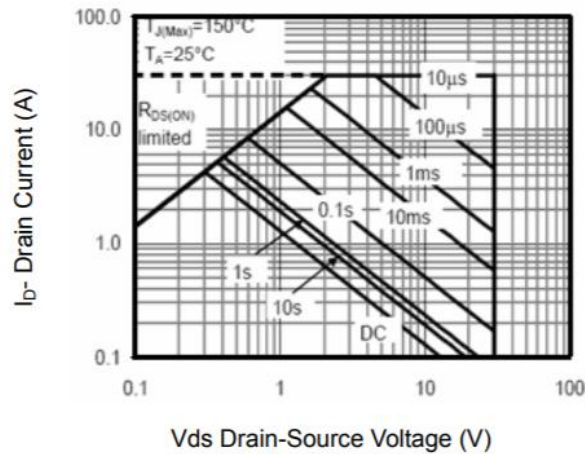

Figure 13 Safe Operation Area

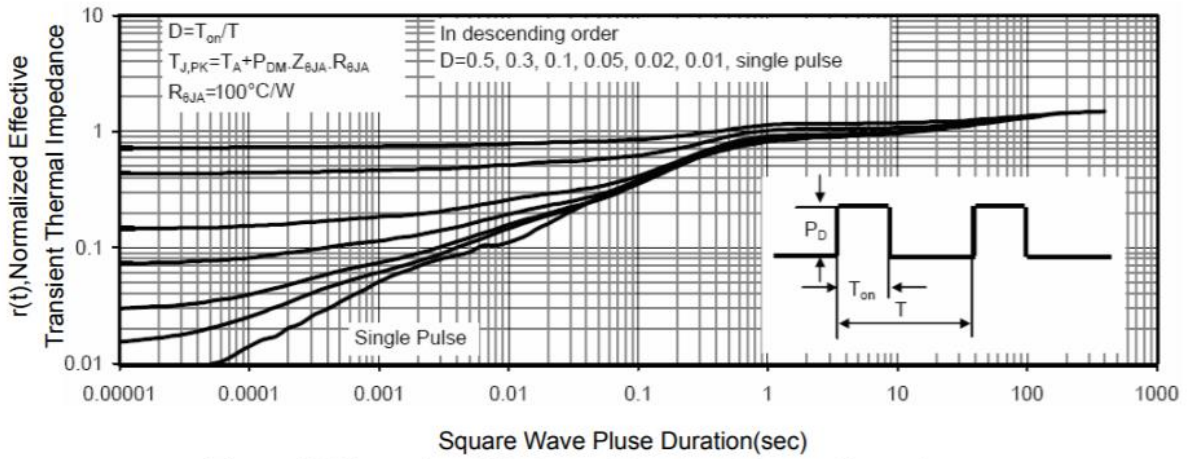

Figure 14 Normalized Maximum Transient Thermal Impedance