

**FRED**  
**Ultrafast Soft Recovery Diode, 30A**

**Features:**

- Ultrafast Recovery
- 175°C operating junction temperature
- High frequency operation
- Low power loss, less RFI and EMI
- Low  $I_R$  value
- High surge capacity
- Epitaxial chip construction

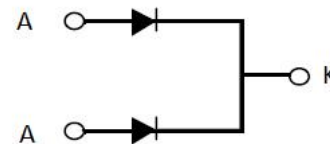
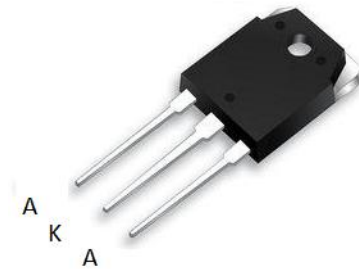

Product Summary	
$V_R$	600 V
$I_{F(AV)}$	2*15A
$t_{rr}$	27 ns

**Description/Applications**

These diodes are optimized to less losses and EMI/RFI in high frequency power conditioning system. The soft recovery behavior of the diodes offers the need as snubber in most applications. These devices are ideally suited for HF welding power converters and other applications where the switching losses are not significant portion of the total losses.

Absolute Maximum Ratings				
Parameter	Symbol	Test Conditions	Values	Units
Repetitive peak reverse voltage	$V_{RRM}$		600	V
Continuous forward current	$I_{F(AV)}$	$T_c = 110^\circ\text{C}$	30	A
Single pulse forward current	$I_{FSM}$	$T_c = 25^\circ\text{C}$	240	
Maximum repetitive forward current	$I_{FRM}$	Square wave, 20kHz	60	
Operating junction	$T_j$		175	$^\circ\text{C}$
Storage temperatures	$T_{stg}$		-55 to +175	$^\circ\text{C}$

Electrical characteristics (Ta=25°C unless otherwise specified)						
Parameter	Symbol	Test Conditions	Min	Typ.	Max.	Units
Breakdown voltage Blocking voltage	$V_{BR}$ , $V_R$	$I_R=100\mu A$	600			V
Forward voltage (Per Diode)	$V_F$	$I_F=15A$		1.35	1.60	
		$I_F=15A, T_j=125^\circ C$		1.20	1.40	
Reverse leakage current(Per Diode)	$I_R$	$V_R=V_{RRM}$			20	$\mu A$
		$T_j=150^\circ C, V_R=600V$			200	
Reverse recovery time(Per Diode)	$t_{rr}$	$I_F=0.5A, I_R=1A, I_{RR}=0.25A$		35	45	ns
		$I_F=1A, V_R=30V, di/dt=200A/\mu s$		27	35	

### Thermal characteristics

Paramter	Symbol	Typ	Units
Junction-to-Case	$R_{\theta JC}$	0.8	$^\circ C/W$

### Electrical performance (typic)

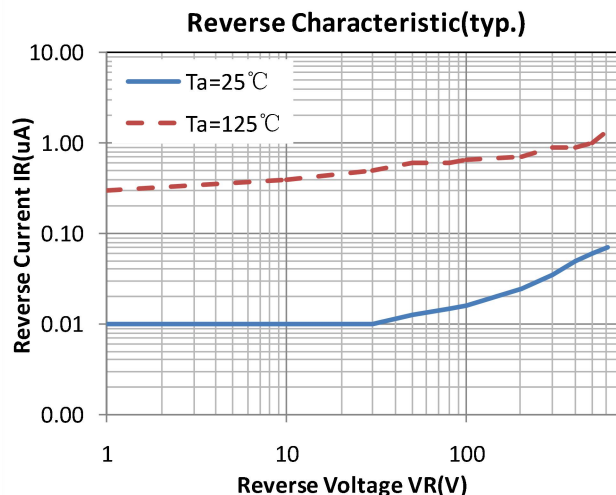
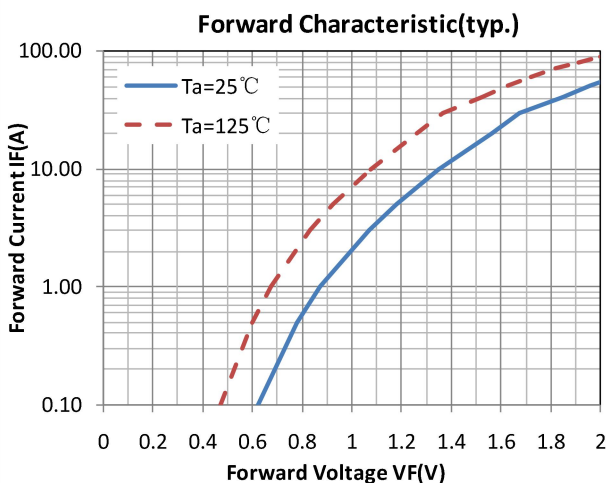

Package Information

TO-3PB PACKAGE

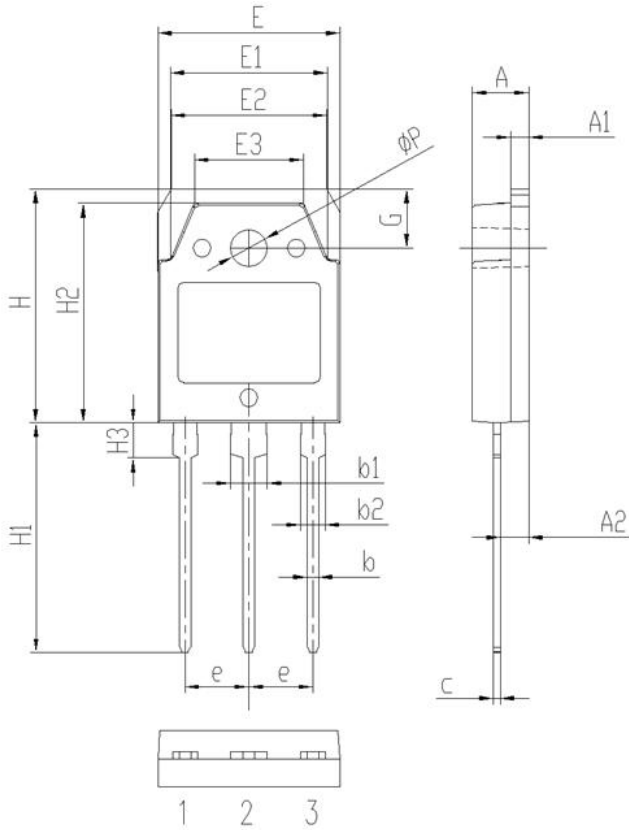

Symbol	Dimensions(millimeters)	
	Min.	Max.
A	4.60	5.00
A1	1.30	1.70
A2	2.20	2.60
b	0.80	1.20
b1	2.90	3.30
b2	1.90	2.30
c	0.40	0.80
e	5.25	5.65
E	15.3	15.7
E1	13.2	13.6
E2	13.1	13.5
E3	9.10	9.50
H	19.7	20.1
H1	19.1	20.1
H2	18.3	18.7
H3	2.80	3.20
G	4.80	5.20
$\Phi P$	3.00	3.40