

Silicon N-Channel Power MOSFET

General Description:

HMF10N70 the silicon N-channel Enhanced VDMOSFETS, is obtained by the self-aligned planar Technology which reduce the conduction loss, improve switching performance and enhance the avalanche energy. The transistor can be used in various power switching circuit for system miniaturization and higher efficiency. The package form is TO-220F, which accords with the RoHS standard.

Features:

- Fast Switching
- Low Gate Charge and R_{ds(on)}
- Low Reverse transfer capacitances
- 100% Single Pulse avalanche energy Test

Applications:

Power switch circuit of adaptor and charger.

Absolute (T_c=25°C unless otherwise specified):

Symbol	Parameter	Rating	Units
V _{DSS}	Drain-to-Source Voltage	700	V
I _D	Continuous Drain Current	10	A
	Continuous Drain Current T _c = 100 °C	6.5	A
I _{DM} ^{a1}	Pulsed Drain Current	40	A
V _{GS}	Gate-to-Source Voltage	±30	V
E _{AS} ^{a2}	Single Pulse Avalanche Energy	1000	mJ
E _{AR} ^{a1}	Avalanche Energy ,Repetitive	100	mJ
I _{AR} ^{a1}	Avalanche Current	4.5	A
dv/dt ^{a3}	Peak Diode Recovery dv/dt	5.0	V/ns
P _D	Power Dissipation	60	W
	Derating Factor above 25°C	0.48	W/°C
T _J , T _{stg}	Operating Junction and Storage Temperature Range	150, -55 to 150	°C
T _L	Maximum Temperature for Soldering	300	°C

V _{DSS}	700	V
I _D	10	A
P _D (T _c =25°C)	60	W
R _{DS(ON)} (TYP)	0.68	Ω

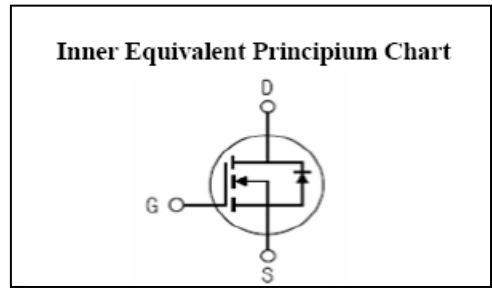
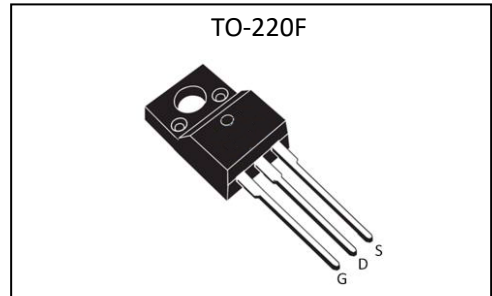

Electrical Characteristics (T_c=25°C unless otherwise specified):

OFF Characteristics						
Symbol	Parameter	Test Conditions	Rating			Units
			Min.	Typ.	Max.	
V _{DSS}	Drain to Source Breakdown Voltage	V _{GS} =0V, I _D =250μA	700	--	--	V
ΔBV _{DSS} /ΔT _J	Bvdss Temperature Coefficient	I _D =250uA, Reference 25°C	--	0.74	--	V/°C
I _{DSS}	Drain to Source Leakage Current	V _{DS} =700V, V _{GS} = 0V, T _a =25°C	--	--	1	μA
		V _{DS} =560V, V _{GS} = 0V, T _a =125°C	--	--	250	
I _{GSS(F)}	Gate to Source Forward Leakage	V _{GS} = +20V	--	--	10	μA
I _{GSS(R)}	Gate to Source Reverse Leakage	V _{GS} = -20V	--	--	-10	μA

ON Characteristics						
Symbol	Parameter	Test Conditions	Rating			Units
			Min.	Typ.	Max.	
R _{DS(ON)}	Drain-to-Source On-Resistance	V _{GS} =10V, I _D =5A	--	0.68	0.75	Ω
V _{GS(TH)}	Gate Threshold Voltage	V _{DS} =V _{GS} , I _D =250μA	2.0	3.0	4.0	V
Pulse width t _p ≤ 380μs, δ ≤ 2%						

Dynamic Characteristics						
Symbol	Parameter	Test Conditions	Rating			Units
			Min.	Typ.	Max.	
g _{fs}	Forward Transconductance	V _{DS} =15V, I _D =5A	--	11	--	S
C _{iss}	Input Capacitance	V _{GS} =0V, V _{DS} =25V f=1.0MHz	--	1900	--	pF
C _{oss}	Output Capacitance		--	170	--	
C _{riss}	Reverse Transfer Capacitance		--	14	--	

Resistive Switching Characteristics						
Symbol	Parameter	Test Conditions	Rating			Units
			Min.	Typ.	Max.	
t _{d(ON)}	Turn-on Delay Time	I _D =10A, V _{DD} =350V V _{GS} =10V, R _G =4.7Ω	--	18	--	ns
t _r	Rise Time		--	32	--	
t _{d(OFF)}	Turn-Off Delay Time		--	52	--	
t _f	Fall Time		--	32	--	
Q _g	Total Gate Charge	I _D =10A, V _{DD} =350V V _{GS} =10V	--	42	--	nC
Q _{gs}	Gate to Source Charge		--	9	--	
Q _{gd}	Gate to Drain ("Miller") Charge		--	16	--	

Source-Drain Diode Characteristics

Symbol	Parameter	Test Conditions	Rating			Units
			Min.	Typ.	Max.	
I_S	Continuous Source Current (Body Diode)		--	--	10	A
I_{SM}	Maximum Pulsed Current (Body Diode)		--	--	40	A
V_{SD}	Diode Forward Voltage	$I_S = 10A, V_{GS} = 0V$	--	--	1.5	V
t_{rr}	Reverse Recovery Time	$I_S = 10A, T_J = 25^\circ C$	--	250	--	ns
Q_{rr}	Reverse Recovery Charge	$di_F/dt = 100A/\mu s, V_{GS} = 0V$	--	2.2	--	μC

Pulse width $t_p \leq 380\mu s, \delta \leq 2\%$

Symbol	Parameter	Typ.	Units
$R_{\theta JC}$	Junction-to-Case	2.08	$^\circ C/W$
$R_{\theta JA}$	Junction-to-Ambient	100	$^\circ C/W$

a¹: Repetitive rating; pulse width limited by maximum junction temperature

a²: $L = 10.0mH$, Start $T_J = 25^\circ C$

a³: $I_{SD} = 10A, di/dt \leq 100A/\mu s, V_{DD} \leq BV_{DS}$, Start $T_J = 25^\circ C$

Test Circuit and Waveform

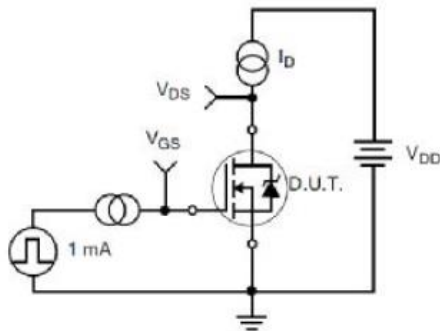

Figure 17. Gate Charge Test Circuit

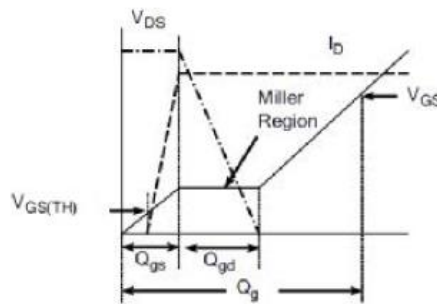

Figure 18. Gate Charge Waveform

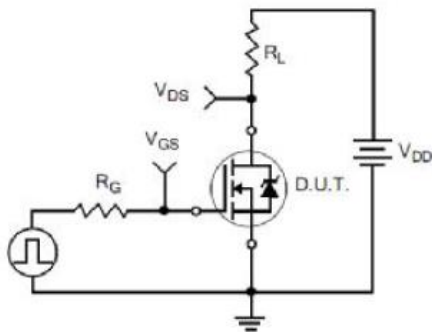

Figure 19. Resistive Switching Test Circuit

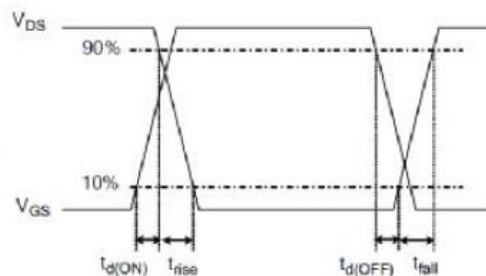

Figure 20. Resistive Switching Waveforms

Characteristics Curve:

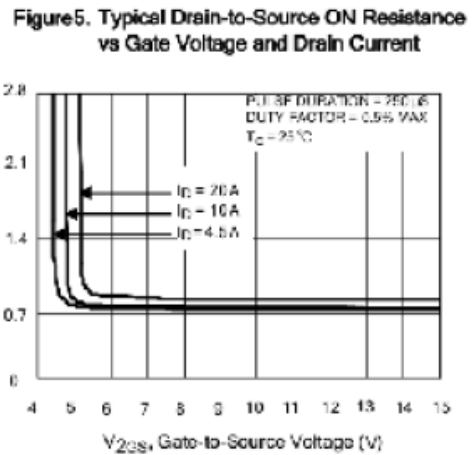
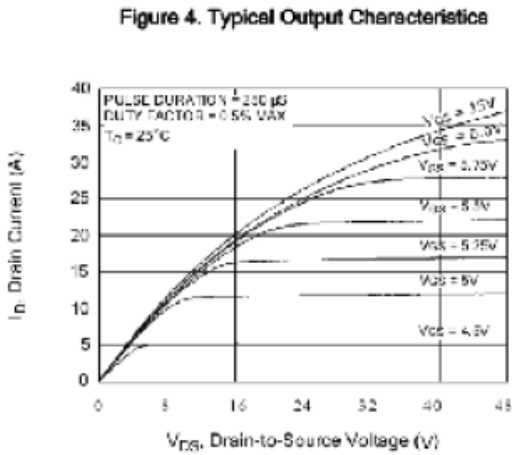
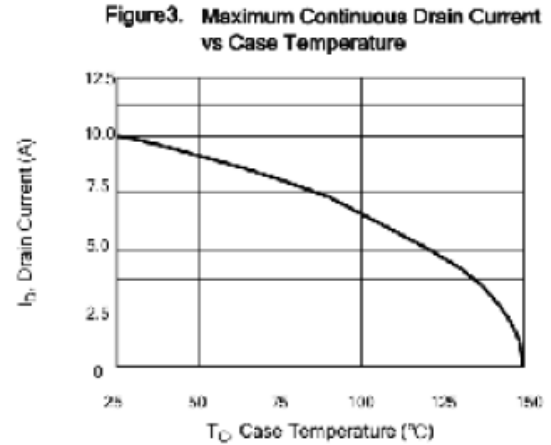
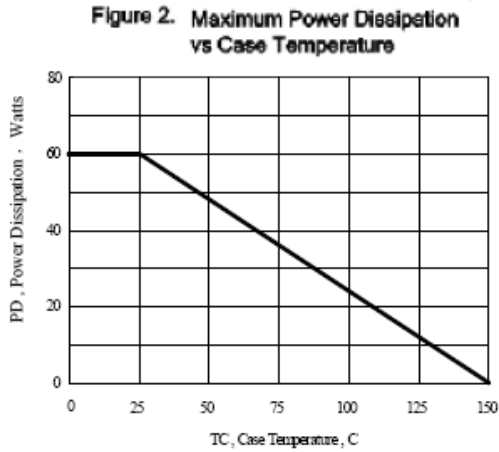
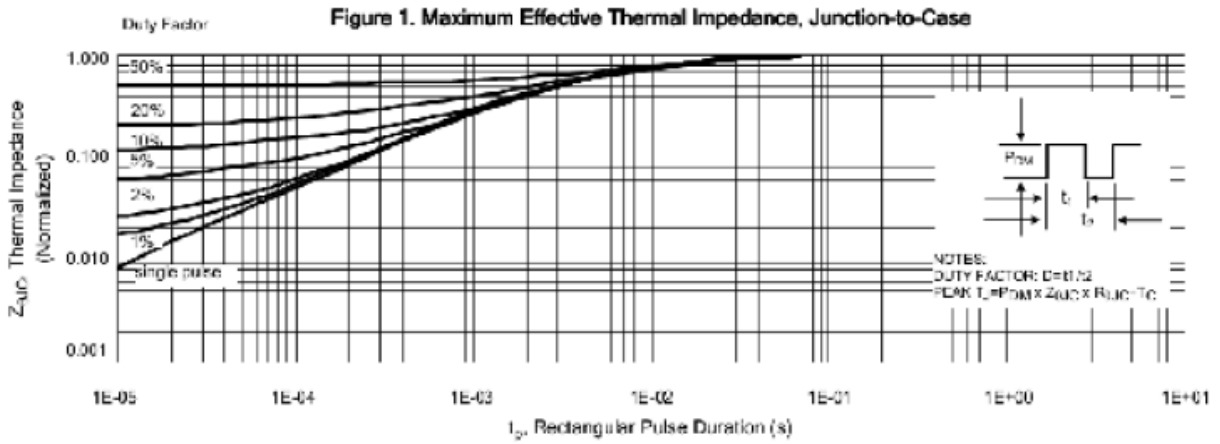

Figure 11. Typical Breakdown Voltage vs Junction Temperature

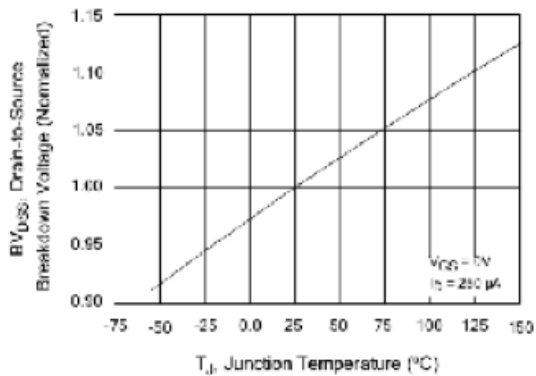

Figure 12. Typical Threshold Voltage vs Junction Temperature

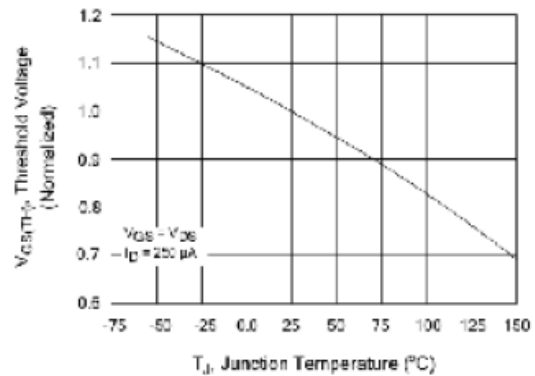

Figure 13. Maximum Forward Bias Safe Operating Area

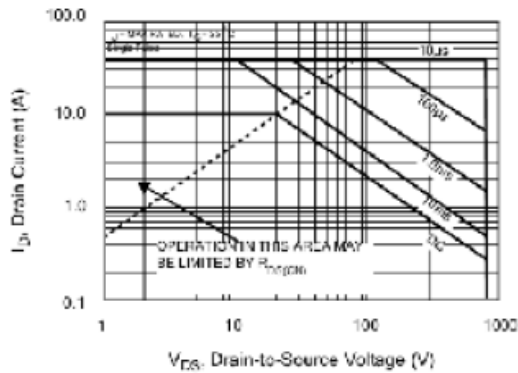

Figure 14. Typical Capacitance vs Drain-to-Source Voltage

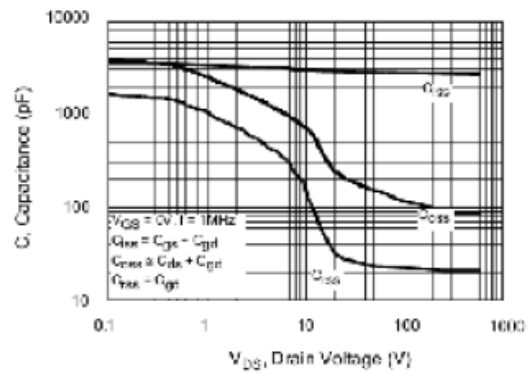

Figure 15. Typical Gate Charge vs Gate-to-Source Voltage

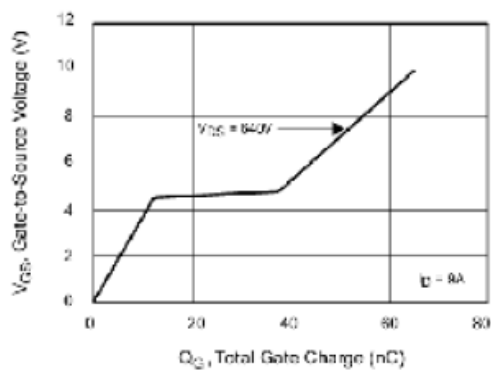

Figure 16. Typical Body Diode Transfer Characteristics

