

## Silicon N-Channel Power MOSFET

### General Description:

HMP15N50 the silicon N-channel Enhanced VDMOSFETS, is obtained by the self-aligned planar Technology which reduce the conduction loss, improve switching performance and enhance the avalanche energy. The transistor can be used in various power switching circuit for system miniaturization and higher efficiency. The package form is TO-247, which accords with the RoHS standard.

### Features:

- Fast Switching
- Low Gate Charge and R<sub>ds(on)</sub>
- Low Reverse transfer capacitances
- 100% Single Pulse avalanche energy Test

### Applications:

- Automotive、DC Motor Control and Class D Amplifier.

V <sub>DSS</sub>	500	V
I <sub>D</sub>	15	A
P <sub>D</sub> (T <sub>C</sub> =25°C)	180	W
R <sub>DS(ON)typ</sub>	0.29	Ω

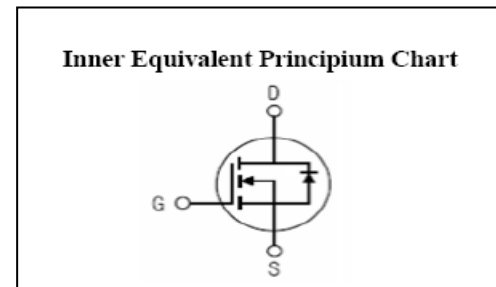
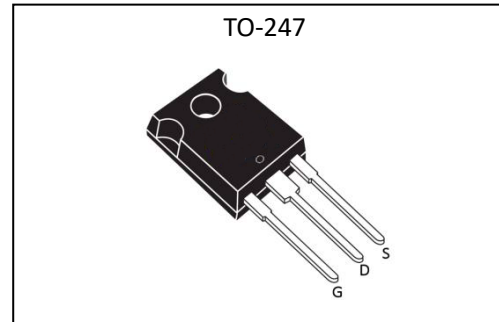

### Absolute (T<sub>C</sub>=25°C unless otherwise specified):

Symbol	Parameter	Rating	Units
V <sub>DSS</sub>	Drain-to-Source Voltage	500	V
I <sub>D</sub>	Continuous Drain Current	15	A
	Continuous Drain Current T <sub>C</sub> = 100 °C	9.5	A
I <sub>DM</sub> <sup>a1</sup>	Pulsed Drain Current	60	A
V <sub>GS</sub>	Gate-to-Source Voltage	±30	V
E <sub>AS</sub> <sup>a2</sup>	Single Pulse Avalanche Energy	1000	mJ
E <sub>AR</sub> <sup>a1</sup>	Avalanche Energy ,Repetitive	200	mJ
I <sub>AR</sub> <sup>a1</sup>	Avalanche Current	6.3	A
dv/dt <sup>a3</sup>	Peak Diode Recovery dv/dt	5.0	V/ns
P <sub>D</sub>	Power Dissipation	180	W
	Derating Factor above 25°C	1.44	W/°C
T <sub>J</sub> , T <sub>stg</sub>	Operating Junction and Storage Temperature Range	150, -55 to 150	°C
T <sub>L</sub>	Maximum Temperature for Soldering	300	°C

## Electrical Characteristics (Tc=25°C unless otherwise specified):

OFF Characteristics						
Symbol	Parameter	Test Conditions	Rating			Units
			Min.	Typ.	Max.	
V <sub>DSS</sub>	Drain to Source Breakdown Voltage	V <sub>GS</sub> =0V, I <sub>D</sub> =250μA	500	--	--	V
ΔBV <sub>DSS</sub> /ΔT <sub>J</sub>	Bvdss Temperature Coefficient	I <sub>D</sub> =250uA, Reference 25°C	--	0.60	--	V/°C
I <sub>DSS</sub>	Drain to Source Leakage Current	V <sub>DS</sub> =500V, V <sub>GS</sub> =0V, T <sub>a</sub> =25°C	--	--	1	μA
		V <sub>DS</sub> =400V, V <sub>GS</sub> =0V, T <sub>a</sub> =125°C	--	--	250	
I <sub>GSS(F)</sub>	Gate to Source Forward Leakage	V <sub>GS</sub> = +30V	--	--	10	μA
I <sub>GSS(R)</sub>	Gate to Source Reverse Leakage	V <sub>GS</sub> = -30V	--	--	-10	μA

ON Characteristics						
Symbol	Parameter	Test Conditions	Rating			Units
			Min.	Typ.	Max.	
R <sub>DS(ON)</sub>	Drain-to-Source On-Resistance	V <sub>GS</sub> =10V, I <sub>D</sub> =7.5A	--	0.29	0.35	Ω
V <sub>GS(TH)</sub>	Gate Threshold Voltage	V <sub>DS</sub> =V <sub>GS</sub> , I <sub>D</sub> =250μA	2.0	3.0	4.0	V
Pulse width tp ≤ 380μs, δ ≤ 2%						

Dynamic Characteristics						
Symbol	Parameter	Test Conditions	Rating			Units
			Min.	Typ.	Max.	
g <sub>fs</sub>	Forward Transconductance	V <sub>DS</sub> =15V, I <sub>D</sub> =7.5A	--	18	--	S
C <sub>iss</sub>	Input Capacitance	V <sub>GS</sub> =0V, V <sub>DS</sub> = 25V f=1.0MHz	--	2400	--	pF
C <sub>oss</sub>	Output Capacitance		--	240	--	
C <sub>rss</sub>	Reverse Transfer Capacitance		--	25.5	--	

Resistive Switching Characteristics						
Symbol	Parameter	Test Conditions	Rating			Units
			Min.	Typ.	Max.	
t <sub>d(ON)</sub>	Turn-on Delay Time	I <sub>D</sub> =15A, V <sub>DD</sub> = 250V V <sub>GS</sub> =10V, R <sub>G</sub> =6.1Ω	--	15	--	ns
t <sub>r</sub>	Rise Time		--	30	--	
t <sub>d(OFF)</sub>	Turn-Off Delay Time		--	50	--	
t <sub>f</sub>	Fall Time		--	40	--	
Q <sub>g</sub>	Total Gate Charge	I <sub>D</sub> =15A, V <sub>DD</sub> =250V V <sub>GS</sub> =10V	--	50	--	nC
Q <sub>gs</sub>	Gate to Source Charge		--	12	--	
Q <sub>gd</sub>	Gate to Drain ( "Miller" ) Charge		--	20	--	

### Source-Drain Diode Characteristics

Symbol	Parameter	Test Conditions	Rating			Units
			Min.	Typ.	Max.	
$I_S$	Continuous Source Current (Body Diode)		--	--	15	A
$I_{SM}$	Maximum Pulsed Current (Body Diode)		--	--	60	A
$V_{SD}$	Diode Forward Voltage	$I_S=15A, V_{GS}=0V$	--	--	1.5	V
$t_{rr}$	Reverse Recovery Time	$I_S=15A, T_j = 25^\circ C$	--	582	--	ns
$Q_{rr}$	Reverse Recovery Charge	$di_F/dt=100A/us, V_{GS}=0V$	--	4.7	--	$\mu C$

Pulse width  $t_p \leq 380\mu s, \delta \leq 2\%$

Symbol	Parameter	Typ.	Units
$R_{\theta JC}$	Junction-to-Case	0.68	$^\circ C/W$
$R_{\theta JA}$	Junction-to-Ambient	40	$^\circ C/W$

a1: Repetitive rating; pulse width limited by maximum junction temperature

a2:  $L=10.0mH, I_D=14A$ , Start  $T_j=25^\circ C$

a3:  $I_{SD}=15A, di/dt \leq 100A/us, V_{DD} \leq BV_{DS}$ , Start  $T_j=25^\circ C$

### Test Circuit and Waveform

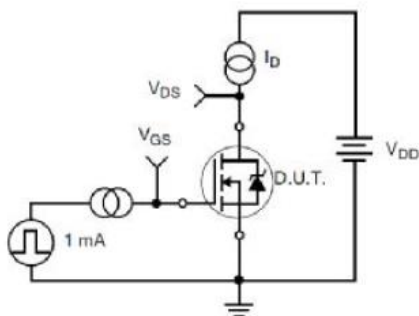

Figure 17. Gate Charge Test Circuit

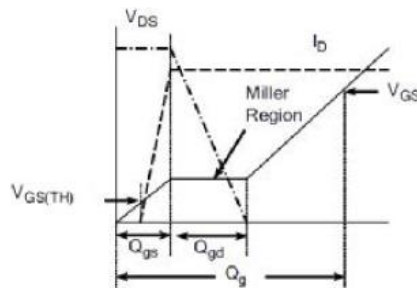

Figure 18. Gate Charge Waveform

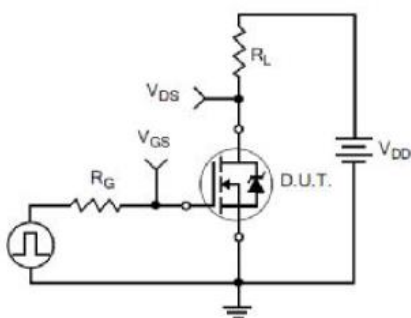

Figure 19. Resistive Switching Test Circuit

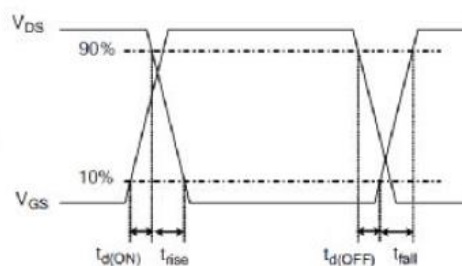
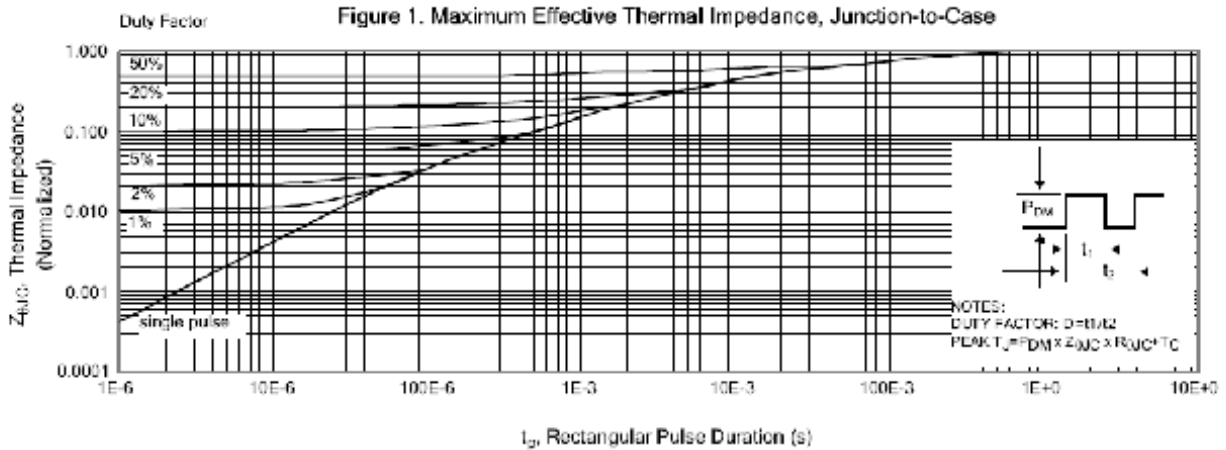
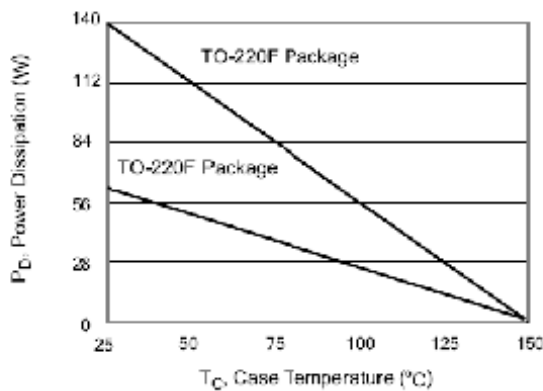

Figure 20. Resistive Switching Waveforms



**Figure 2. Maximum Power Dissipation vs Case Temperature**



**Figure 3. Maximum Continuous Drain Current vs Case Temperature**

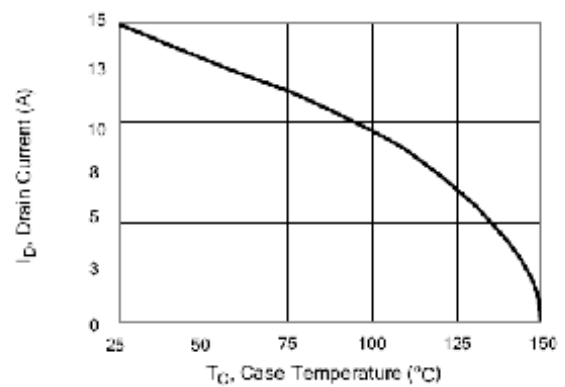

**Figure 4. Typical Output Characteristics**

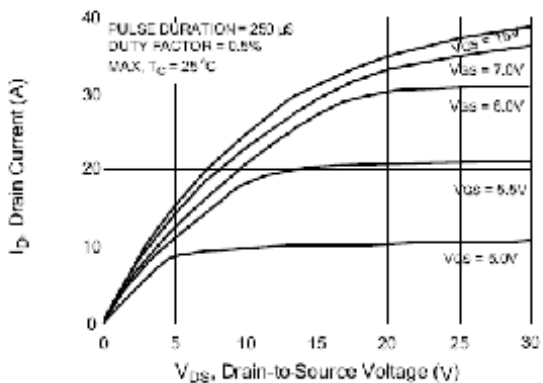

**Figure 5. Typical Drain-to-Source ON Resistance vs Gate Voltage and Drain Current**

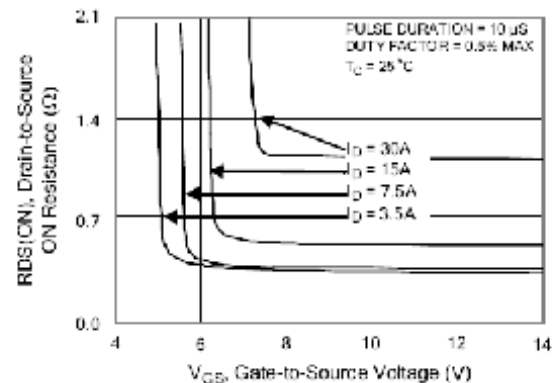

Figure 6. Maximum Peak Current Capability

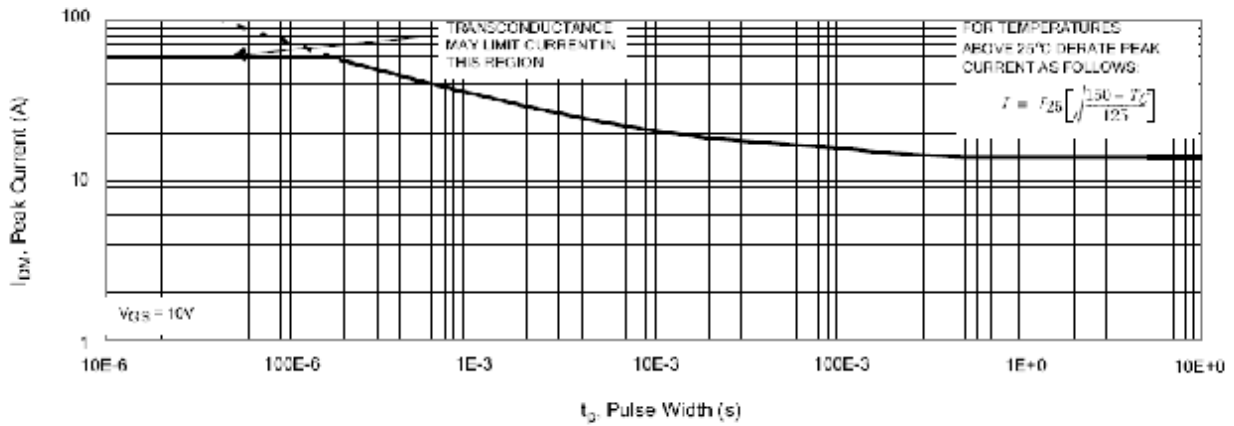

Figure 7. Typical Transfer Characteristics

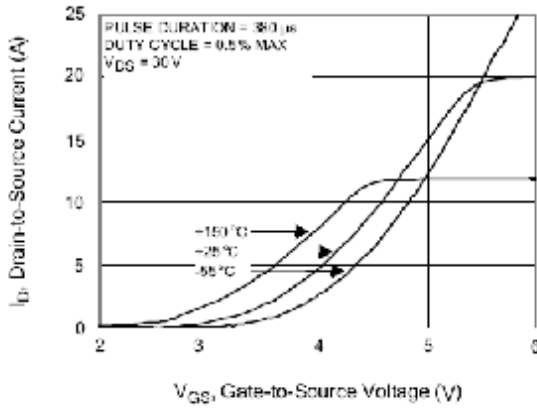

Figure 8. Unclamped Inductive Switching Capability

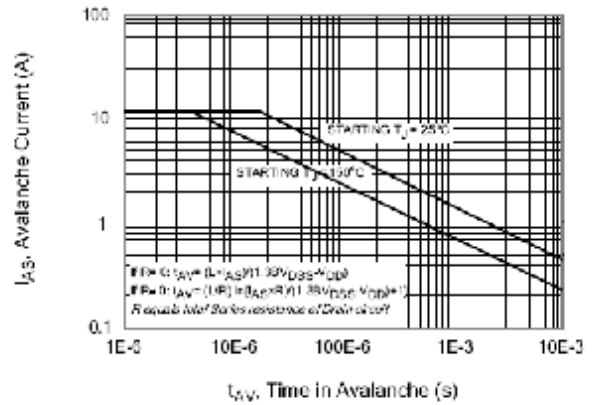

Figure 9. Typical Drain-to-Source ON Resistance vs Drain Current

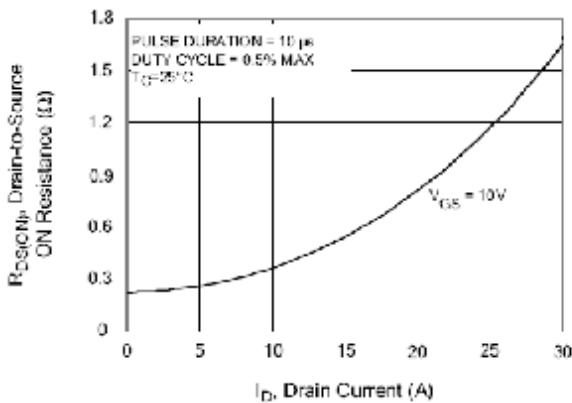

Figure 10. Typical Drain-to-Source ON Resistance vs Junction Temperature

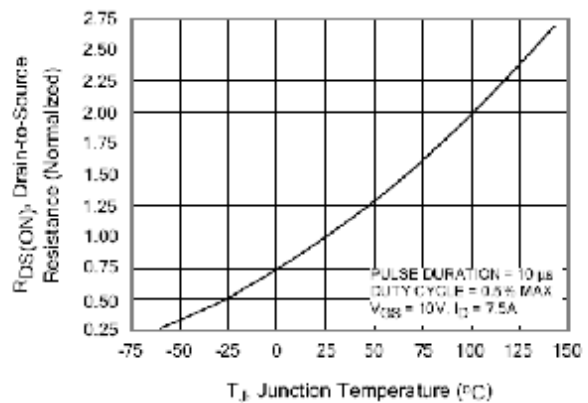

Figure 11. Typical Breakdown Voltage vs Junction Temperature

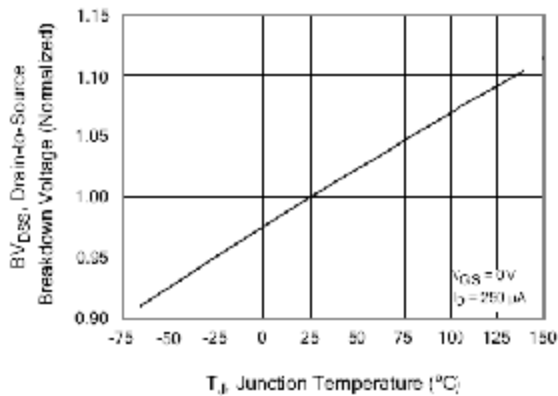

Figure 12. Typical Threshold Voltage vs Junction Temperature

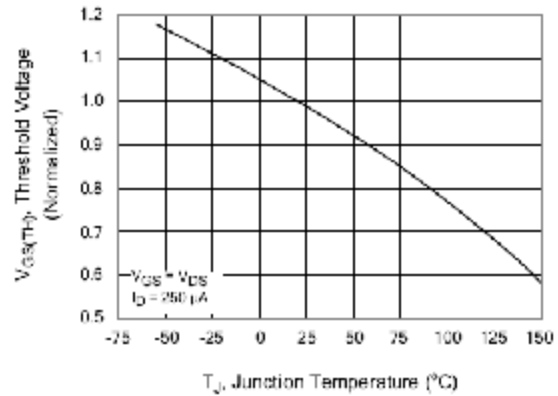

Figure 13. Maximum Forward Bias Safe Operating Area

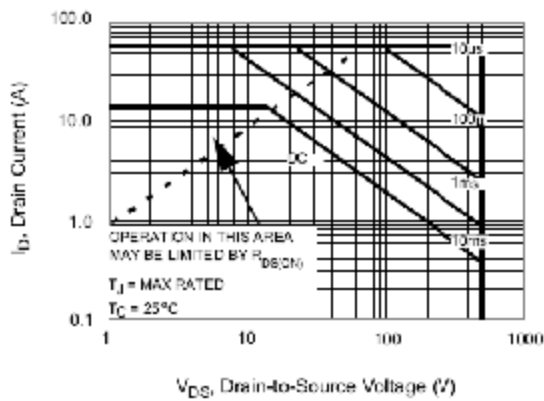

Figure 14. Typical Capacitance vs Drain-to-Source Voltage

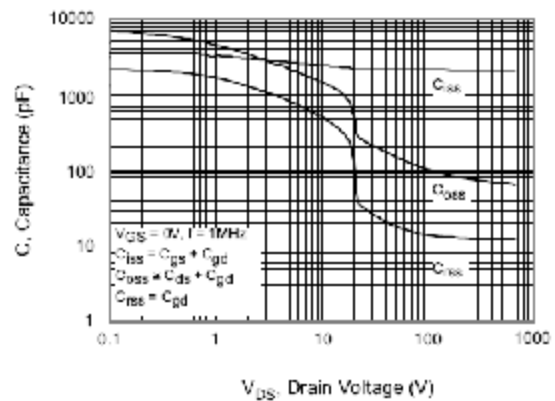

Figure 15. Typical Gate Charge vs Gate-to-Source Voltage

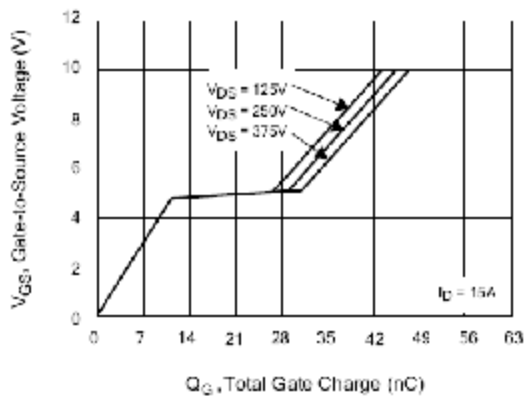
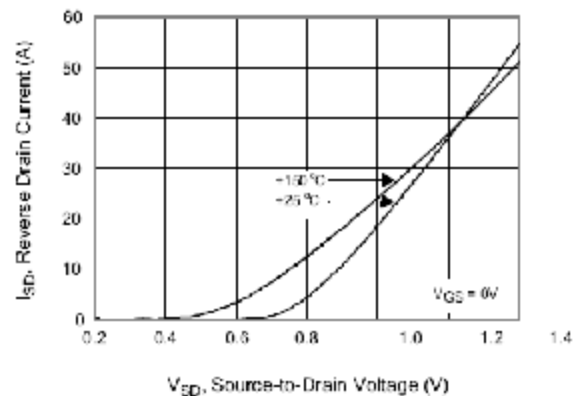

Figure 16. Typical Body Diode Transfer Characteristics



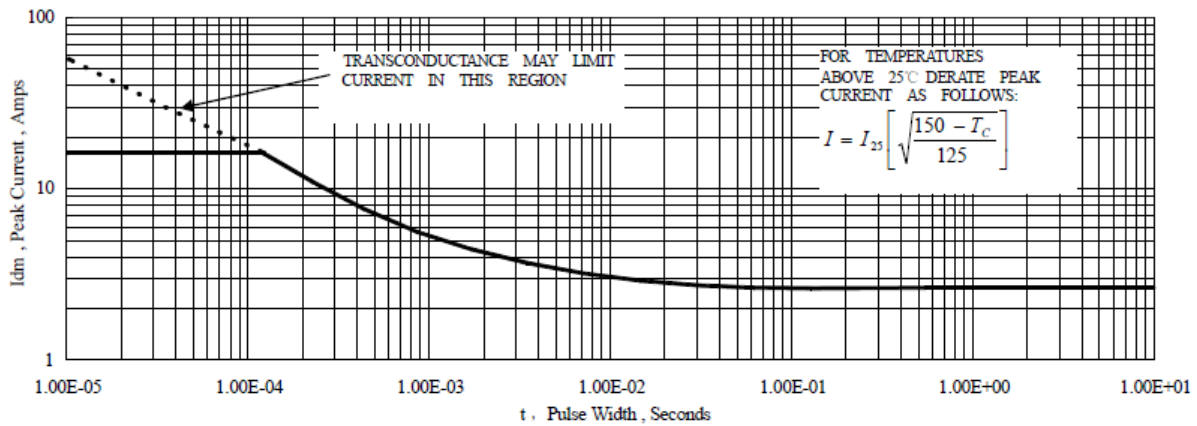

Figure 6 Maximum Peak Current Capability

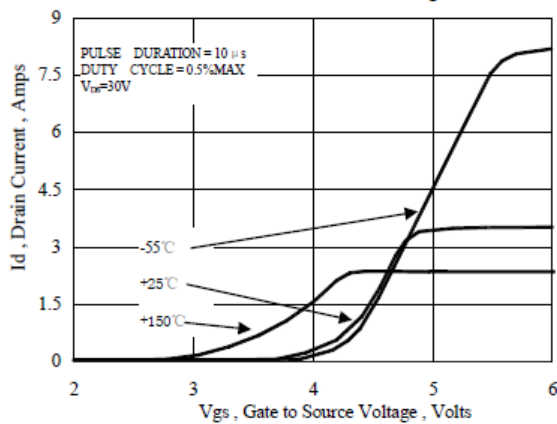

Figure 7 Typical Transfer Characteristics

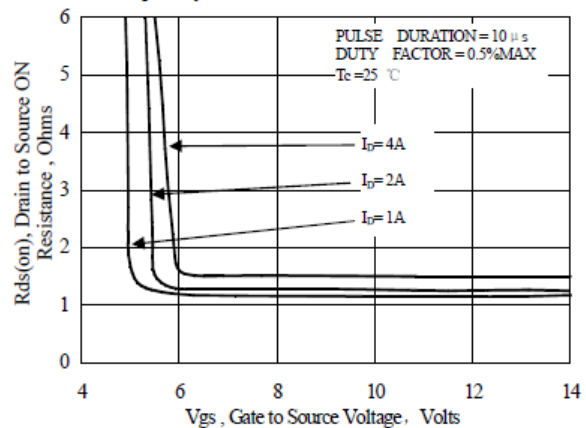

Figure 8 Typical Drain to Source ON Resistance vs Gate Voltage and Drain Current

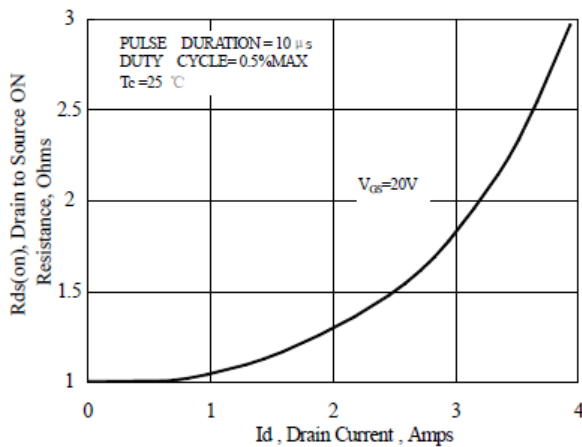

Figure 9 Typical Drain to Source ON Resistance vs Drain Current

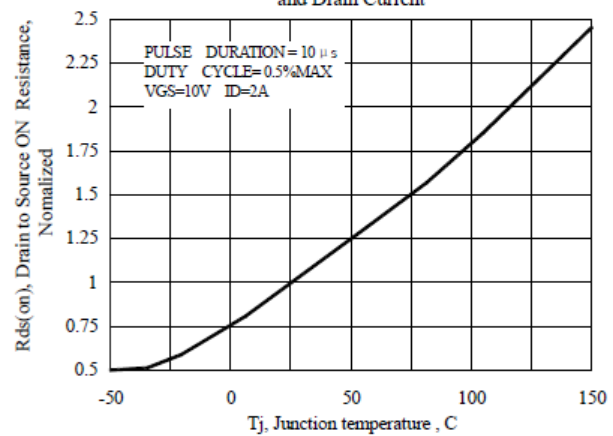

Figure 10 Typical Drain to Source ON Resistance vs Junction Temperature